



## Digital relative humidity & temperature sensor RHT03

### 1. Feature & Application:

- \*High precision
- \*Capacitive type
- \*Full range temperature compensated
- \*Relative humidity and temperature measurement
- \*Calibrated digital signal
- \*Outstanding long-term stability
- \*Extra components not needed
- \*Long transmission distance, up to 100 meters
- \*Low power consumption
- \*4 pins packaged and fully interchangeable

### 2. Description:

RHT03 output calibrated digital signal. It applies exclusive digital-signal-collecting-technique and humidity sensing technology, assuring its reliability and stability. Its sensing elements are connected with 8-bit single-chip computer.

Every sensor of this model is temperature compensated and calibrated in accurate calibration chamber and the calibration-coefficient is saved in type of programme in OTP memory, when the sensor is detecting, it will cite coefficient from memory.

Small size & low consumption & long transmission distance(100m) enable RHT03 to be suited in all kinds of harsh application occasions. Single-row packaged with four pins, making the connection very convenient.

### 3. Technical Specification:

Model	RHT03	
Power supply	3.3-6V DC	
Output signal	digital signal via MaxDetect 1-wire bus	
Sensing element	Polymer humidity capacitor	
Operating range	humidity 0-100%RH;	temperature -40~80Celsius
Accuracy	<b>humidity +-2%RH</b> (Max +-5%RH);	temperature +-0.5Celsius
Resolution or sensitivity	humidity 0.1%RH;	temperature 0.1Celsius
Repeatability	humidity +-1%RH;	temperature +-0.2Celsius
Humidity hysteresis	+-0.3%RH	
Long-term Stability	+-0.5%RH/year	
Interchangeability	fully interchangeable	

### 4. Dimensions: (unit---mm)

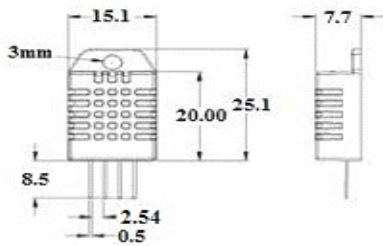

Pin sequence number: 1 2 3 4 (from left to right direction).

Pin	Function
1	VDD—power supply
2	DATA—signal
3	NULL
4	GND

## 5. Electrical connection diagram:

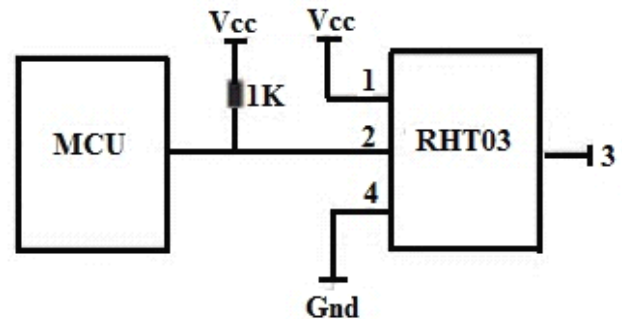

## 6. Operating specifications:

### (1) Power and Pins

Power's voltage should be 3.3-6V DC. When power is supplied to sensor, don't send any instruction to the sensor within one second to pass unstable status. One capacitor valued 100nF can be added between VDD and GND for wave filtering.

### (2) Communication and signal

MaxDetect 1-wire bus is used for communication between MCU and RHT03. ( MaxDetect 1-wire bus is specially designed by MaxDetect Technology Co., Ltd. , it's different from Maxim/Dallas 1-wire bus, so it's incompatible with Dallas 1-wire bus.)

### Illustration of MaxDetect 1-wire bus:

#### DATA=16 bits RH data+16 bits Temperature data+8 bits check-sum

Example: MCU has received 40 bits data from RHT03 as

0000 0010 1000 1100    0000 0001 0101 1111    1110 1110  
 16 bits RH data                  16 bits T data                  check sum

Here we convert 16 bits RH data from binary system to decimal system,

0000 0010 1000 1100    →    652

Binary system                  Decimal system

**RH=652/10=65.2%RH**

Here we convert 16 bits T data from binary system to decimal system,

0000 0001 0101 1111    →    351

Binary system                  Decimal system

**T=351/10=35.1°C**

When highest bit of temperature is 1, it means the temperature is below 0 degree Celsius.

Example: 1000 0000 0110 0101, T= minus 10.1°C

16 bits T data

Sum=0000 0010+1000 1100+0000 0001+0101 1111=1110 1110

**Check-sum**=the last 8 bits of Sum=1110 1110

When MCU send start signal, RHT03 change from standby-status to running-status. When MCU finishes sending the start signal, RHT03 will send response signal of 40-bit data that reflect the relative humidity and temperature to MCU. Without start signal from MCU, RHT03 will not give response signal to MCU. One start signal for one response data from RHT03 that reflect the relative humidity and temperature. RHT03 will change to standby status when data collecting finished if it don't receive start signal from MCU again.

See below figure for overall communication process, **the interval of whole process must beyond 2 seconds.**

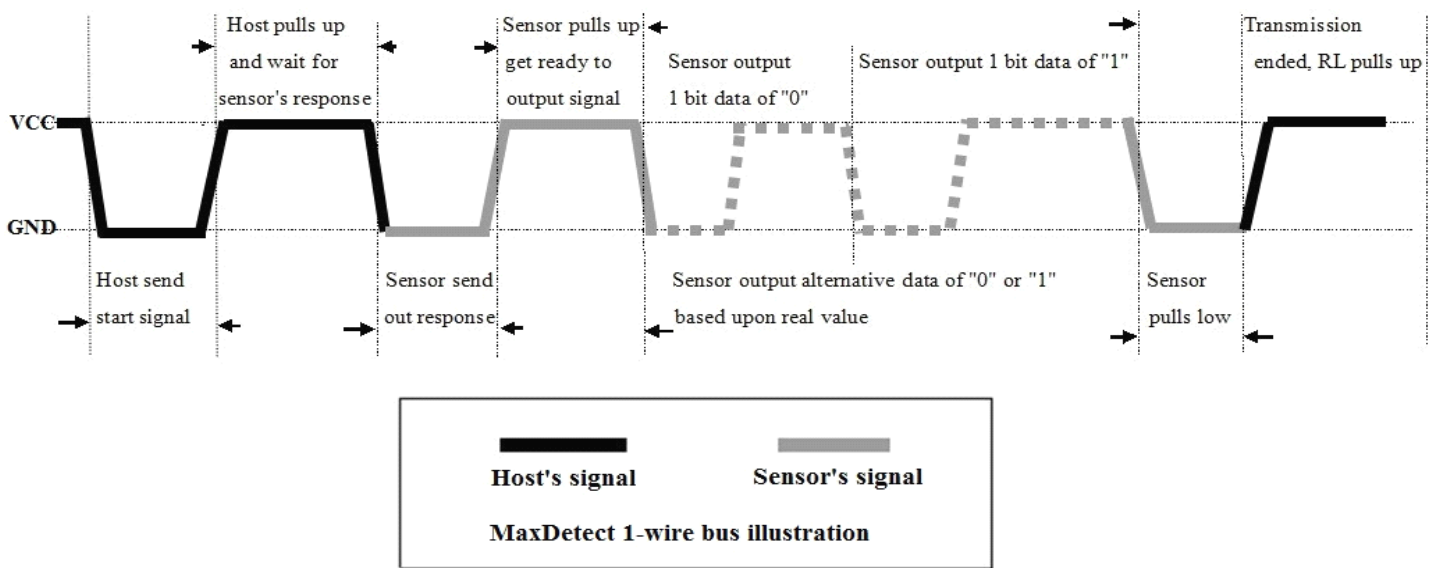

1) Step 1: MCU send out start signal to RHT03 and RHT03 send response signal to MCU

Data-bus's free status is high voltage level. When communication between MCU and RHT03 begins, MCU will pull low data-bus and this process must beyond at least 1~10ms to ensure RHT03 could detect MCU's signal, then MCU will pulls up and wait 20-40us for RHT03's response.

When RHT03 detect the start signal, RHT03 will pull low the bus 80us as response signal, then RHT03 pulls up 80us for preparation to send data. See below figure:

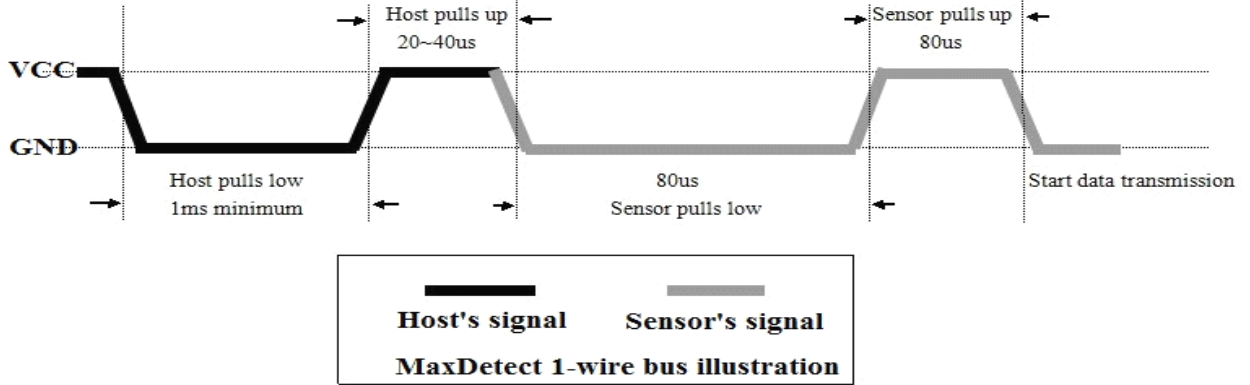

## 2). Step 2: RHT03 send data to MCU

When RHT03 is sending data to MCU, every bit's transmission begin with low-voltage-level that last 50us, the following high-voltage-level signal's length decide the bit is "1" or "0". See below figures:

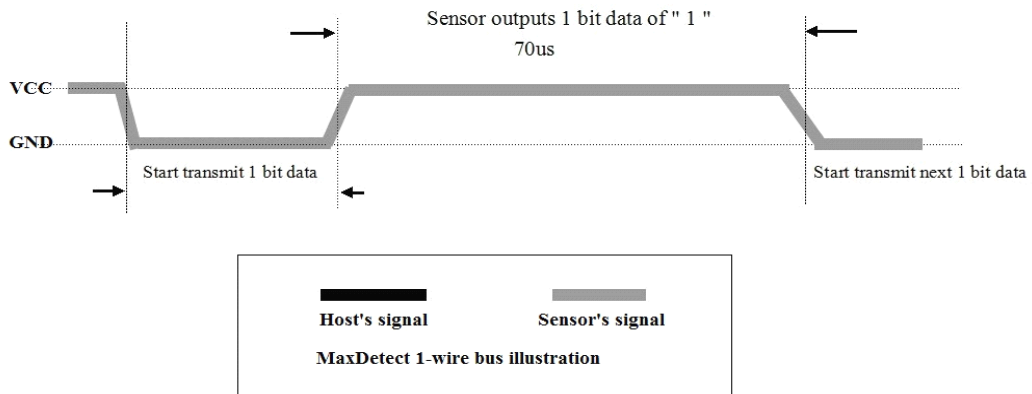
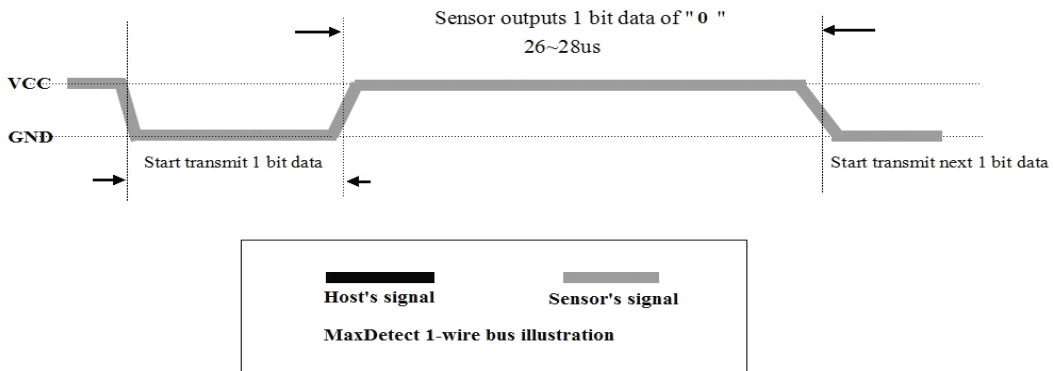

## Attention:

If signal from RHT03 is always high-voltage-level, it means RHT03 is not working properly, please check the electrical connection status.

## 7. Electrical Characteristics:

Items	Condition	Min	Typical	Max	Unit
Power supply	DC	3.3	5	6	V
Current supply	Measuring	1		1.5	mA
	Stand-by	40	Null	50	uA
Collecting period	Second		2		Second

## 8. Attentions of application:

### (1) Operating and storage conditions

We don't recommend the applying RH-range beyond the range stated in this specification. The RHT03 sensor can recover after working in abnormal operating condition to calibrated status, but will accelerate sensors' aging.

### (2) Attentions to chemical materials

Vapor from chemical materials may interfere RHT03's sensitive-elements and debase RHT03's sensitivity.

### (3) Disposal when (1) & (2) happens

Step one: Keep the RHT03 sensor at condition of Temperature 50~60Celsius, humidity <10%RH for 2 hours;

Step two: After step one, keep the RHT03 sensor at condition of Temperature 20~30Celsius, humidity >70%RH for 5 hours.

### (4) Attention to temperature's affection

Relative humidity strongly depend on temperature, that is why we use temperature compensation technology to ensure accurate measurement of RH. But it's still be much better to keep the sensor at same temperature when sensing.

RHT03 should be mounted at the place as far as possible from parts that may cause change to temperature.

### (5) Attentions to light

Long time exposure to strong light and ultraviolet may debase RHT03's performance.

### (6) Attentions to connection wires

The connection wires' quality will effect communication's quality and distance, high quality shielding-wire is recommended.

### (7) Other attentions

\* Welding temperature should be bellow 260Celsius.

\* Avoid using the sensor under dew condition.

\* Don't use this product in safety or emergency stop devices or any other occasion that failure of RHT03 may cause personal injury.